

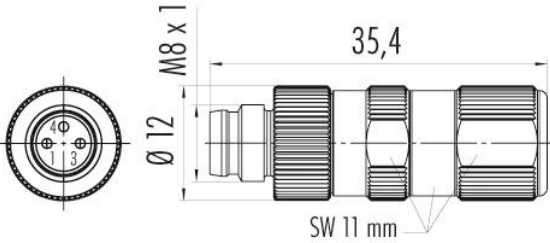

## 768 Series: Male M8 Cable Connectors with biatec® Quick Termination



- 3 and 4 pole male and female cable connectors
- Fits for cables with:
  - wire cross-sections from 0,14 to 0,34 mm<sup>2</sup>
  - Core diameters with insulation 1,0 – 1,6 mm
  - cable diameters from 3-5 mm
  - wire insulation material PVC, TPE
- Can be used with all Binder cables:
  - 3 x 0,25 mm<sup>2</sup>, 4 x 0,25 mm<sup>2</sup>, 3 x 0,34 mm<sup>2</sup>,
  - 4 x 0,34 mm<sup>2</sup> PVC or PUR
- Protection degree IP67
- Contact material : copper alloy  
Contact surface: gold
- Housing made of diecasted zinc
- Insulation material: PA

## 768 Series: Male M8 Cable Connectors with biatec® Quick Termination

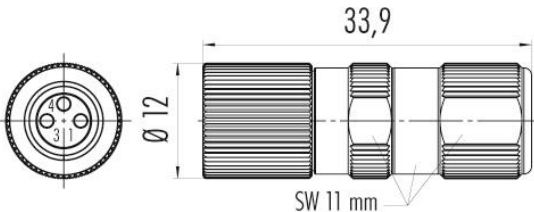
description/ picture	Drawing	Contacts	Ordering nr.
<p>Biatec® male cable connector</p> 		<p>3</p> <p>4</p>	<p>99-3379-400-03</p> <p>99-3383-400-04</p>
<p>Biatec® female cable connector</p> 		<p>3</p> <p>4</p>	<p>99-3400-400-03</p> <p>99-3376-400-04</p>

## 768 Series: Male M8 Cable Connectors with biatec® Quick Termination

### Mounting instruction:

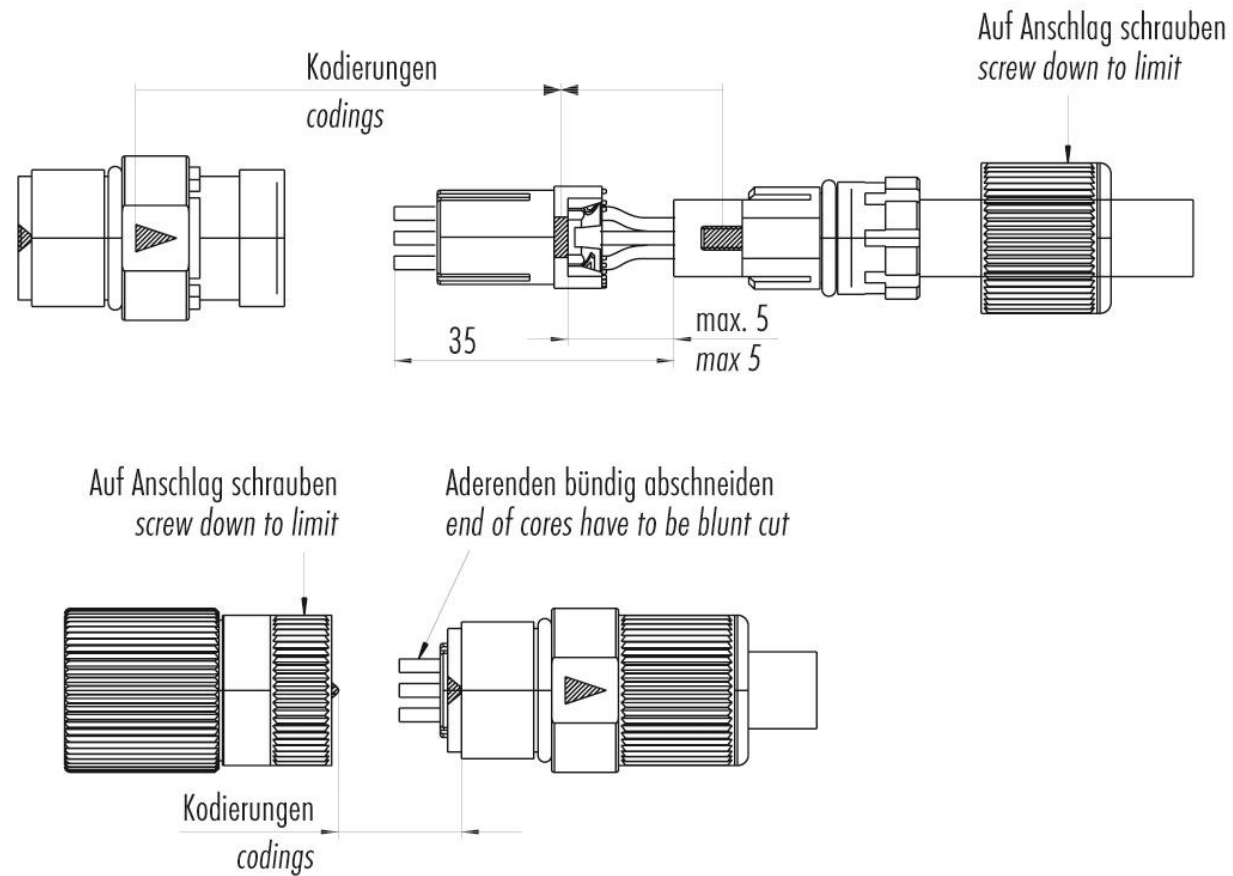

## 768 Series: Male M8 Cable Connectors with biatec® Quick Termination

### Assembly steps:

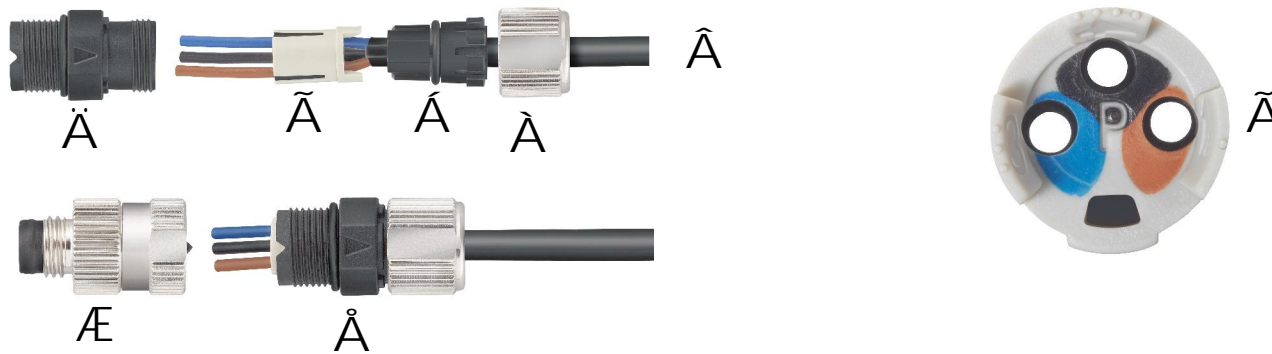

1. Check if cable features (diameter, cross section, material etc.) are suitable for the connector.
2. Bead pressing screw À and pinch ring Á on cable Ã.
3. Strip cable minimum 35 mm and chose the wire carrier ã (black 0,14 – 0,25 mm<sup>2</sup>, white 0,25 – 0,34 mm<sup>2</sup>)
4. Bead through wires and push them forwards the cable coating as far as possible (maximum gap 5 mm). Mind that the correct colours are in the appropriate carriers.
5. Push pre-wiring unit Ä into threaded sleeve (codings have to be in line with each other). Screw pressing screw to threaded sleeve Ä.
6. Single wires have to be blunt cut.
7. Screw Pre-assembled unit to male or female contact carrier Æ (Codings have to be in line with each other).



0,14 – 0,25 mm<sup>2</sup>



0,25 – 0,34 mm<sup>2</sup>

## 768 Series: Male M8 Cable Connectors with biatec® Quick Termination

Component part picture:

